

**CONTINENTAL**  
GIRBAU®

**CONTINENTAL**  
GIRBAU INC  
**CG75-85**



**PRO|SERIES™ II**

CG20-30 | CG30-40 | CG55-65  
CG50-60 | CG75-85 | CG115-25 | CG165-75 | CG195-205

DRYING TUMBLERS FOR ON-PREMISE LAUNDRIES

LINT COMPARTMENT MUST BE CLEANED DAILY



# PRO|SERIES II™

Pro-Series II Dryers are engineered for the ultimate in efficiency, programmability and ease-of-use. Complete with properly balanced airflow, heat input and cylinder volume, the Pro-Series II line delivers high-quality results and features that dramatically increase laundry production and extend linen life.

Pro-Series II Drying Tumblers are designed with quality components, easy-to-use programmable controls and unique features that reduce linen loss, ensure safety and boost laundry throughput. Durably constructed for years of constant use, Pro-Series II Drying Tumblers work in concert with Continental washer-extractors and are backed by an industry leading factory warranty.

## PRODUCTIVITY & EFFICIENCY REDEFINED

### ENERGY-EFFICIENCY

Several key features contribute to heightened energy-efficiency on Pro-Series II Dryers, including instant electronic spark ignition; a modular electrical system for added reliability and easy servicing; and a multiple burner heat system to efficiently and quickly reach desired temperatures. Pro-Series II delivers quick drying thanks to carefully balanced heat energy input and airflow. Perfectly balanced airflow prevents extra wear on fabrics and cuts drying time. The heat system is enclosed thereby capturing intake air and preheating it before entering the tumbler — reducing energy costs without increasing dry time.

### CUT OWNERSHIP COSTS WITH PRO-SERIES II

Engineered for quick drying and efficiency, Pro-Series II Dryers balance drying time and BTU consumption to reduce energy usage and labor costs. Simultaneously, they maximize laundry throughput by reducing dry cycle times to more closely match wash cycle times. While most dry cycles run 30 percent longer than wash cycles, Pro-Series II Dryers dry laundry more quickly — improving productivity.

By reducing dry cycle times to match wash cycle times, laundries operate at top efficiency and throughput. Pro-Series II Dryers balance quick drying with energy-efficiency for unmatched results and a reduction in costs.

### ERGONOMIC & EASY TO MAINTAIN

Ergonomic and easy to maintain, Pro-Series II Dryers feature self-cleaning lint screens that support maximum airflow. Further contributing to ease of maintenance are conveniently accessible components and an automatic backdraft damper to prevent outside air from entering the laundry room. Because ergonomics matter, the tumblers feature oversized steel doors with reinforced metal door bars and hinges — simplifying loading and unloading!

### COMPACT DESIGN OF CG55-65

The Pro-Series II compact CG55-65 tumbler fits through a standard 36-inch door, takes up less space and offers more drying capacity than most 50-pound capacity drying tumblers! At 34.5 inches in width, the CG55-65 tumbler is super-slim so it fits into smaller spaces. Yet, thanks to innovative engineering, it also offers big capacity and productivity!



DUAL MOTORS

OVERSIZED LINT COMPARTMENT

## UNMATCHED DURABILITY

Durability characterizes Pro-Series II. The tumblers feature rugged cylinders; dual motors with overload protection; steel front, side and top panels coated inside and out with electrostatically applied, baked-on paint for superior bonding and corrosion resistance; an all-belt drive system with cast iron pulleys and permanently sealed bearings for quiet, low-maintenance operation; and durable kick-plates and cart bumpers to protect tumblers from nicks and scrapes.

An exclusive annealed stainless steel backplate (standard on all models except CG115-25, CG165-75 and CG195-205) contributes to longer machine life and also reduces friction against tumbling laundry — extending linen life.



## ENGINEERED FOR HIGH PERFORMANCE

### AXIAL AIRFLOW FOR SMALL-LOAD EFFICIENCY

#### CG20-30, CG30-40 & CG55-65 MODELS

Pro-Series II small-capacity dryers feature axial airflow, a system that directs heated air through the load from back to front. Perforated cylinders and drum lifters maximize airflow and tumbling action while also preventing tangling. The result is fast and efficient drying — exactly what on-premise laundries want!

### RADIAL AIRFLOW FOR LARGER LOADS

#### CG50-60, CG75-85, CG115-25, CG165-75 & CG195-205 MODELS

Pro-Series II large-capacity drying tumblers are designed with radial airflow — a system that captures heated intake air and distributes it evenly throughout the cylinder. Radial airflow ensures maximum load separation for big loads and bulky items and utilizes the tumbler's complete capacity for quick, even drying. As heated air is released from the bottom of the basket, liners, which are rotated from the bottom to the top, fall and separate throughout the entire cylinder. Simultaneously, heated air is pushed through and around the load — eliminating hot spots.

AXIAL AIRFLOW

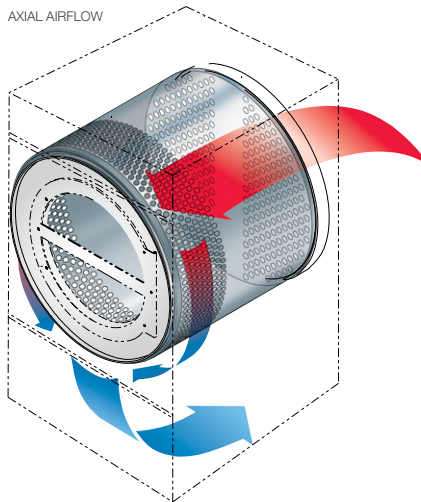

RADIAL AIRFLOW

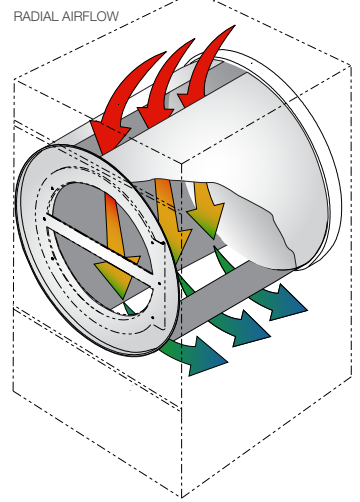

## IMPORTANCE OF SAFETY

### ISS FIRE SENSING & EXTINGUISHING

Continental understands the importance of safety. That's why we've equipped Pro-Series II dryers with an optional Integrated Sprinkler System (ISS), a sensing and extinguishing device that squelches dryer fires before they get out of control. ISS, which is available on gas and steam units, is always active — even after a load is complete — offering laundries added protection when a laundry is unattended. If ISS sensors detect a fire inside the dryer drum, the drum rotates and distributes water vapor — saturating laundry and extinguishing the fire. ISS continues to monitor the condition of the dryer and restarts if fire is again detected.





## INNOVATIVE TECHNOLOGY & CONTROL FLEXIBILITY

Pro-Series II Dryers offer two programmable controls - the Dual Digital Control or the Microprocessor Control.

### DUAL DIGITAL CONTROL AVAILABLE ON ALL MODELS

The Dual Digital Control is simple to use, efficient and reliable. It allows the operator to choose one of four temperature selections, heat and cool down cycle time and a single push-to-start operation.

### MICROPROCESSOR CONTROL AVAILABLE ON ALL MODELS

Continental's Microprocessor Control is designed for greater flexibility and efficiency. Equipped with a multitude of features, the control offers up to 20 programmable cycles; a reminder to clean the lint screen; an anti-wrinkle and extended tumble feature that initiates unheated tumble action after the end-of-cycle signal to reduce the occurrence of wrinkles in unattended loads; an external end-of-cycle output to aid attendants in noticing when a load is complete; and auditing information on the display. With multiple programmable cycle types — time-dry, auto-dry or Continental's moisture sensing drying (optional on CG20-30 through CG75-85, standard on CG115-25, CG165-75 and CG195-205) — Pro-Series Dryers offer the ultimate in drying technology and load management control.



DUAL DIGITAL CONTROL



MICROPROCESSOR CONTROL

### MOISTURE SENSING TECHNOLOGY STANDARD — CG20-30 THROUGH CG75-85; OPTIONAL — CG115-25, CG165-75, CG195-205

Continental's Linen Life Extension (LLE) moisture sensing system is very reliable and extremely accurate. Featuring 20 programmable cycles with up to 12 programmable dryness levels and additional programmable heat time, LLE can target any dryness level from zero to 40 percent. To ensure accurate moisture readings, the LLE system provides an extremely large load-to-surface contact area. Unlike some moisture sensing systems available, Continental's LLE system uses the entire surface area of the lifters within the dryer cylinder as sensors. This increase in load contact surface area provides extremely accurate moisture readings. When the load has reached its preset target level of dryness, the control shuts the dryer off — saving energy, time and labor. The result? Dry good experience less damage with up to 31 percent less fiber loss. LLE effectively reduces over drying, resulting fabric damage and cuts energy and labor costs.



# PRO|SERIES II

## PRODUCT SPECIFICATIONS

	CG20-30	CG30-40	CG55-65	CG50-60	CG75-85	CG115-25	CG165-75	CG195-205
Capacity <i>lbs</i>	up to 30	up to 40	up to 65	up to 60	up to 85	up to 125	up to 175	up to 205
Airflow Type	Axial	Axial	Axial	Radial	Radial	Radial	Radial	Radial
Cylinder Diameter <i>inch (mm)</i>	26.5 (673)	30 (762)	33 (838)	37 (939)	37 (939)	44 (1118)	50.75 (1289)	50.75 (1289)
Cylinder Depth <i>inch (mm)</i>	24 (610)	30 (762)	35 (889)	30 (762)	36 (914)	41 (1041)	42.5 (1080)	50 (1270)
Cylinder Volume <i>cu ft (m<sup>3</sup>)</i>	7.7 (0.22)	12.3 (0.35)	17.3 (0.49)	18.6 (0.53)	22.4 (0.63)	36.1 (1.02)	49.7 (1.41)	58.5 (1.66)
Net Weight <i>lbs (kg)</i>								
Gas/Electric	299 (135)	361 (164)	435 (197)	545 (247)	615 (279)	1275 (578)	1575 (714)	1741 (790)
Steam	299 (135)	361 (164)	—	545 (247)	615 (279)	1375 (624)	1675 (760)	1808 (820)
Crated Weight <i>lbs (kg)</i>								
Gas/Electric	332 (151)	394 (179)	476 (216)	602 (273)	677 (307)	1338 (607)	1667 (756)	1818 (825)
Steam	332 (151)	394 (179)	—	602 (273)	677 (307)	1446 (656)	1776 (806)	1885 (855)
Machine Width <i>inch (mm)</i>	28 (711)	31.5 (800)	34.5 (876)	38.62 (981)	38.62 (981)	46.38 (1178)	53.12 (1349)	53.12 (1349)
Machine Depth <i>inch (mm)</i>	40.87 (1038)	46.87 (1191)	53.62 (1362)	48.25 (1226)	54.25 (1378)	67.92 (1725)	68.85 (1749)	76.35 (1939)
Machine Height <i>inch (mm)</i>								
Gas/Electric	63.87 (1622)	63.87 (1622)	66.72 (1695)	76.62 (1946)	76.62 (1946)	85.7 (2177)	94 (2388)	94 (2388)
Steam	63.87 (1622)	63.87 (1622)	—	80 (2032)	80 (2032)	83.5 (2121)	94 (2388)	94 (2388)
Door Opening <i>inch (mm)</i>	22.68 (576)	22.68 (576)	26.89 (683)	26.89 (683)	26.89 (683)	26.89 (683)	26.89 (683)	26.89 (683)
Floor to Door <i>inch (mm)</i>	27.5 (699)	27.5 (699)	26.89 (683)	28.75 (730)	28.75 (730)	31.38 (797)	33.86 (860)	33.86 (860)
Shipping Dimensions <i>inch (mm) (WxDxH)</i>	30 x 43 x 69 (762x1092x1753)	33 x 49 x 69 (838x1245x1753)	35.5 x 59 x 72 (902x1499x1829)	41.5 x 52.1 x 81 (1054x1323x2057)	41.5 x 56.4 x 81 (1054x1433x2057)	48.5 x 72 x 90 (1232x1829x2286)	58 x 74.5 x 99 (1473x1892x2515)	55.63 x 81.25 x 99 (1413x2064x2515)
Motor Power <i>HP (kW)</i>	2 @ 1/4 (0.19)	2 @ 1/4 (0.19)	2 @ 1/2 (0.37)	1/2 (0.37)	3/4 (0.56)	—	—	—
Reversing Motor Power <i>HP (kW)</i>								
Cylinder	—	—	—	1/3 (0.25)	1/3 (0.25)	3/4 (0.56)	3/4 (0.56)	3/4 (0.56)
Fan	—	—	—	1/3 (0.25)	1/3 (0.25)	1 (0.75)	3 (2.24)	3 (2.24)
Exhaust Diameter <i>inch (mm)</i>	6 (152)	8 (203)	8 (203)	8 (203)	8 (203)	10 (254)	12 (300)	12 (300)
Exhaust Air Flow <i>cfm (l/s)</i>								
Gas/Steam	500 (236)	650 (307)	700 (330)	750 (354)	920 (434)	1600 (755)	2450 (1156)	2450 (1156)
Electric	500 (236)	650 (307)	700 (330)	750 (354)	750 (354)	1600 (755)	2450 (1156)	2450 (1156)
Electric Heating <i>kW</i>	12	24	27	30	30	60	—	—
Gas Connection <i>inch</i>	1/2 NPT	1/2 NPT	1/2 NPT	1/2 NPT	1/2 NPT	3/4 NPT.	1 NPT	1 NPT
Gas Heating <i>BTU/h (Kcal/h)</i>	64,000 (16,120)	90,000 (22,670)	112,000 (28,230)	130,000 (32,759)	165,000 (41,580)	270,000 (68,040)	395,000 (99,500)	425,000 (107,124)
Steam Connection <i>inch</i>	3/4 NPT	3/4 NPT	—	3/4 NPT	3/4 NPT	3/4 NPT / 3/4 NPT	3/4 NPT/1 NPT	3/4 NPT/1 NPT
Steam Heating <i>BTU/h (kW)</i> at 100 PSI (6.9 bar)	135,000 (39.6)	166,000 (48.6)	—	178,000 (52)	210,000 (61.6)	405,000 (118.5)	648,000 (294.2)	648,000 (294.2)
BHP Consumption <i>BHP</i> at 100 PSI (6.9 bar)	3.9	4.8	—	5.1	6.1	11.7	18.8	18.8
Gas/Steam Amp ( <i>Rev. Amp</i> )								
120/208-240/60/1	12.0/6.7	12.0/6.7	9.2/6.5	—	—	—	—	—
120/60/1	—	—	—	9.3	13.8	—	—	—
208-240/60/1	—	—	—	—	—	—	—	—
200-208/240/60/3	3.2/3.2 (4.0/4.0)	3.2/3.2 (4.0/4.0)	4.0/ 3.9 (4.0/4.5)	2.8/2.8 (4.0/4.0)	3.8/3.8 (4.3/4.3)	(7.7)	(13.5)	(14)
440/60/3	—	—	—	1.4 (1.9) steam only	1.9 (2.1) steam only	(3.8) steam only	(6.4) steam only	(7) steam only
460-480/60/3	1.6 (2.0)	1.6	—	1.4 (1.9)	1.9 (2.1)	(3.9)	(6.7)	(7)
Electric Amp ( <i>Rev. Amp</i> )								
208/60/1	64 (64)	122 (122)	129 (129)	—	—	—	—	—
240/60/1	57 (57)	107 (107)	115 (115)	—	—	152	—	—
200-208/60/3	37 (37)	71 (71)	79 (79)	89 (88)	89 (88)	—	—	—
240/60/3	33 (33)	62 (62)	65 (65)	79 (78)	79 (78)	—	—	—
440/60/3	—	—	—	41 (41)	41 (41)	—	—	—
460-480/60/3	16 (16)	31 (31)	—	—	—	—	—	—
480/60/3	—	—	—	38 (38)	38 (38)	76.1	—	—

\* Product specifications and details are subject to change without notice. For the most current and complete technical specifications, architectural line drawings and warranty information, please visit [www.cglaundry.com](http://www.cglaundry.com).

**CONTINENTALCARE** | 3-YR LIMITED PARTS WARRANTY  
BUY WITH COMPLETE CONFIDENCE

Durably constructed for years of constant use, Pro-Series II Drying Tumblers are backed by an industry-leading 3-year ContinentalCare warranty.

# CONTINENTAL GIRBAU INC. & GIRBAU GROUP

Continental Girbau Inc. (Continental) was established in 1995 as the North American subsidiary of the commercial laundry equipment manufacturer, Girbau Group, headquartered in Vic, Spain. Family owned, Girbau employs more than 600 people throughout its corporate headquarters in Vic and 15 subsidiaries throughout the world. It markets its industrial and commercial laundry products to more than 90 countries worldwide.

## THE TOTAL LAUNDRY SOLUTION

Continental delivers the total laundry solution to vended, on-premise and industrial laundries throughout North America. As the provider of highly efficient batch tunnel washers, washer-extractors, drying tumblers, feeders, ironers, folders and related machinery, Continental serves the complete laundry production and efficiency needs of virtually any application. Proven durable and reliable, Continental laundry systems are engineered for unrivaled productivity, efficiency and ease of use.

## OUR MISSION: YOUR SUCCESS

Continental's mantra – "Our Mission: Your Success" – reflects the company's commitment to its distributors and customers. We offer robust laundry systems backed by unrivaled customer care.

## SIZING & CONFIGURATION

Every laundry operation is unique, with a distinctive set of production and efficiency goals. Uniquely, Pro-Series Drying Tumblers offer the flexibility and programmability to meet any need – boosting production and lowering labor and utility usage. Continental's team of experts work closely with facilities to properly size equipment for improved laundry room efficiency and productivity.

## FINANCING

Financing allows you to retain full ownership of your business and its assets while helping to preserve your cash, liquidity and revolving lines of credit for emergency use, working capital and other investments. Through CustomSelect™ Financing, Continental Girbau offers flexible financing and competitive fixed rates to all qualifying applicants.

## ENVIRONMENTALLY FRIENDLY

Continental laundry products meet rigorous environmental and safety standards established by the International Organization for Standardization (ISO), including ISO9001 and ISO14001. Ever focused on laundry efficiency, Continental Girbau is a member of the U.S. Green Building Council (USGBC), a 501(c)(3) nonprofit that developed the Leadership in Energy and Environmental Design (LEED) Green Building Rating System.

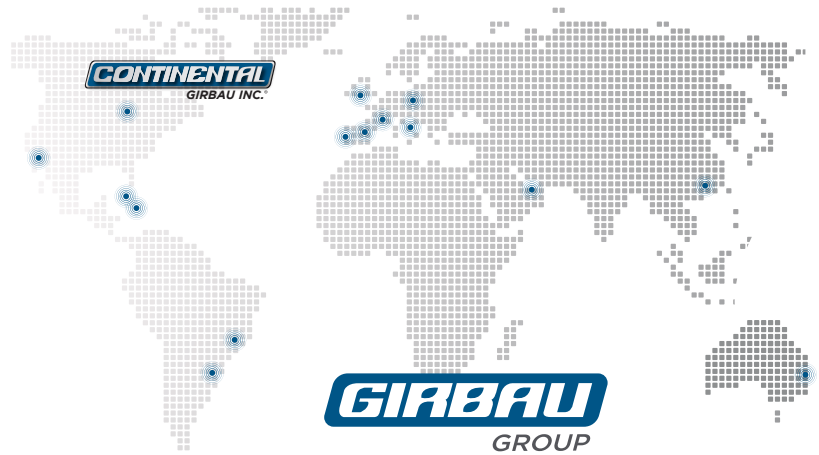

## DISTRIBUTED BY:



www.cgilaundry.com • 800-256-1073  
2500 State Road 44 • Oshkosh, WI 54904 • 920-231-8222 • Fax 920-231-4666