

RMG033

ON-PREMISE G-FLEX HARD-MOUNT WASHER-EXTRACTOR

ARCHITECTURAL/MECHANICAL
PRODUCT SPECIFICATIONS

PRODUCT SPECS

Capacity <i>lbs</i>	33
Cylinder Diameter <i>inch</i>	24.4
Cylinder Depth <i>inch</i>	16.4
Cylinder Volume <i>cu ft</i>	4.5
Net Weight <i>lbs</i>	525
Crated Weight <i>lbs</i>	580
Machine Dimensions <i>inch</i> WxDxH	29.5 x 32.25 x 52.9
Door Opening <i>inch</i>	12.9
Floor to Door <i>inch</i>	20
Shipping Dimensions <i>inch</i> WxDxH	30.6 x 37.9 x 58.8
Washing Speed <i>rpm</i>	44
Spin Speed <i>rpm</i>	44/100/380/540/635/760
G-force	50/100/140/200
Static Force Transmitted <i>lbs</i>	721
Dynamic Force Transmitted <i>lbs</i>	1387
Frequency of Dynamic Force <i>Hz</i>	12.7
Available Voltages/Wire Conductor/Amp	208-240/60/1, 2W+G, 10
Drain Diameter <i>inch</i>	3
Water Inlets <i>inch</i>	2 @ 3/4
Recommended Water Pressure <i>PSI</i>	30-60
Water Flow <i>gal/min</i>	16
Steam Connection <i>inch</i>	1/2
Total Power <i>kW</i>	0.85

* Specifications subject to change without notice or obligation. Contact Poseidon Textile Care at (800) 256-1073 for dimensions not shown or for clarification.

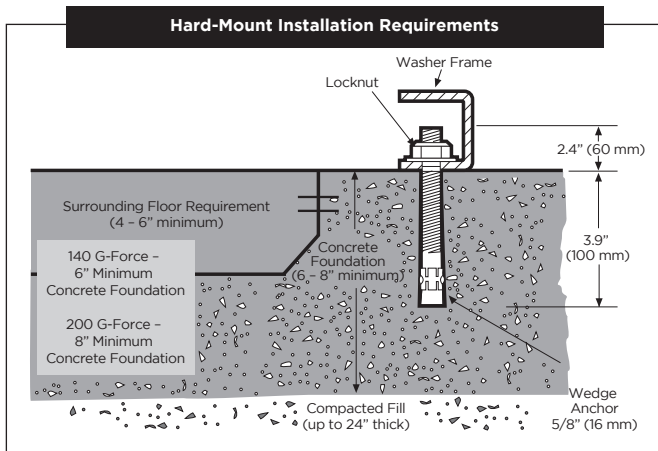
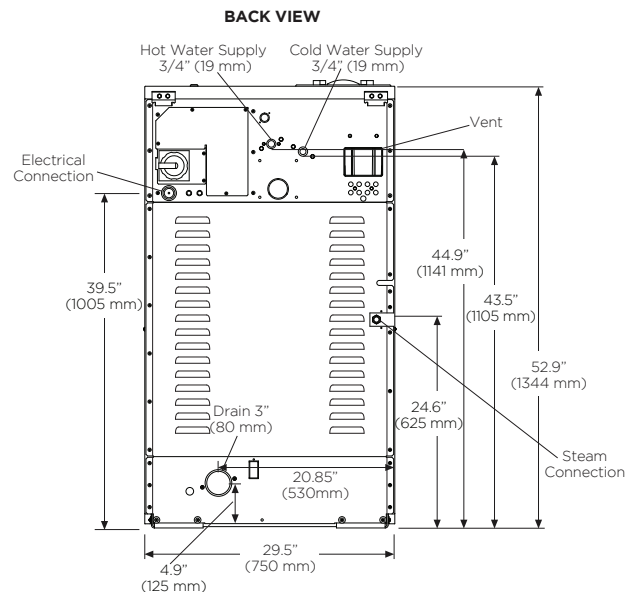
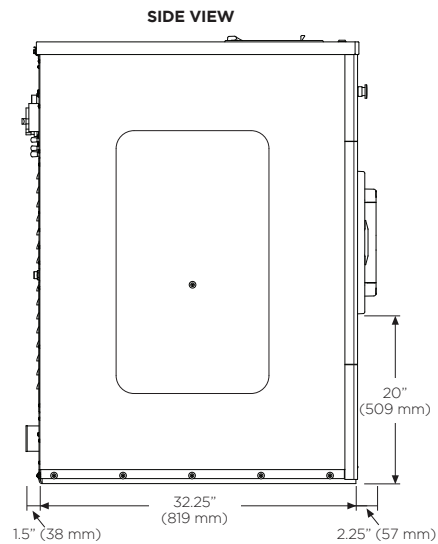
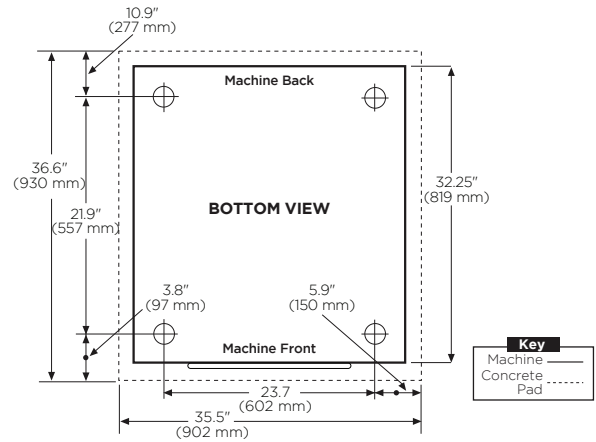

RMG040

ON-PREMISE G-FLEX HARD-MOUNT WASHER-EXTRACTOR

ARCHITECTURAL/MECHANICAL
PRODUCT SPECIFICATIONS

PRODUCT SPECS

Capacity <i>lbs</i>	40
Cylinder Diameter <i>inch</i>	24.4
Cylinder Depth <i>inch</i>	21.6
Cylinder Volume <i>cu ft</i>	6
Net Weight <i>lbs</i>	562
Crated Weight <i>lbs</i>	624
Machine Dimensions <i>inch</i> WxDxH	29.5 x 41.8 x 52.9
Door Opening <i>inch</i>	12.9
Floor to Door <i>inch</i>	20
Shipping Dimensions <i>inch</i> WxDxH	30.6 x 43.1 x 58.8
Washing Speed <i>rpm</i>	47
Spin Speed <i>rpm</i>	47/100/380/540/635/760
G-force	50/100/140/200
Static Force Transmitted <i>lbs</i>	805
Dynamic Force Transmitted <i>lbs</i>	1828
Frequency of Dynamic Force <i>Hz</i>	12.7
Available Voltages/Wire Conductor/Amp	208-240/60/1, 2W+G, 10
Drain Diameter <i>inch</i>	3
Water Inlets <i>inch</i>	2 @ 3/4
Recommended Water Pressure <i>PSI</i>	30-60
Water Flow <i>gal/min</i>	16
Steam Connection <i>inch</i>	1/2
Total Power <i>kW</i>	0.8

* Specifications subject to change without notice or obligation. Contact Poseidon Textile Care at (800) 256-1073 for dimensions not shown or for clarification.

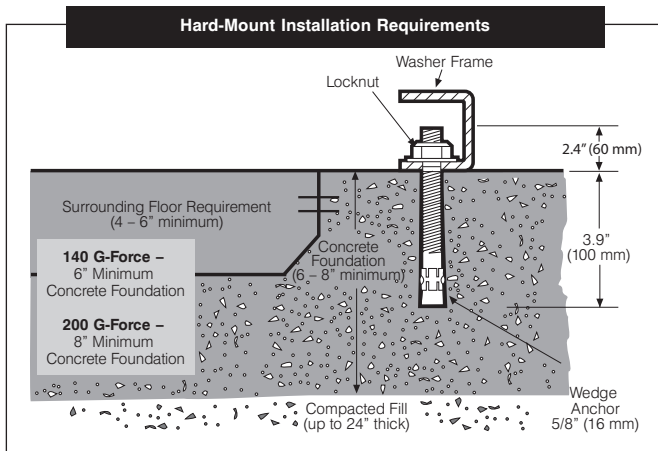
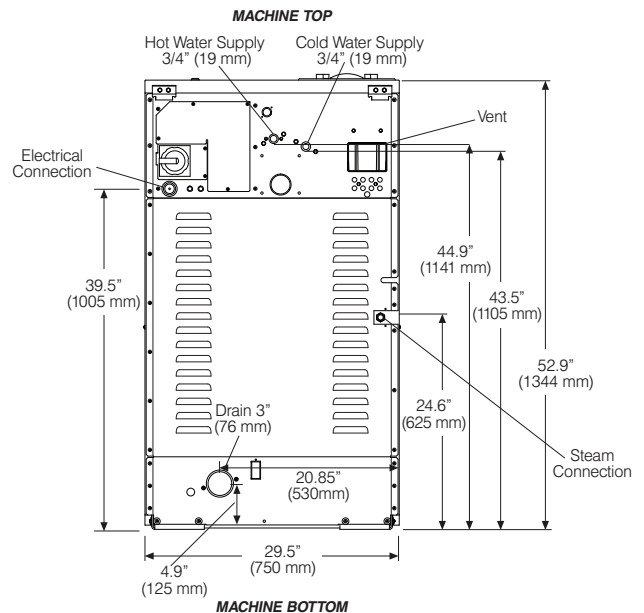
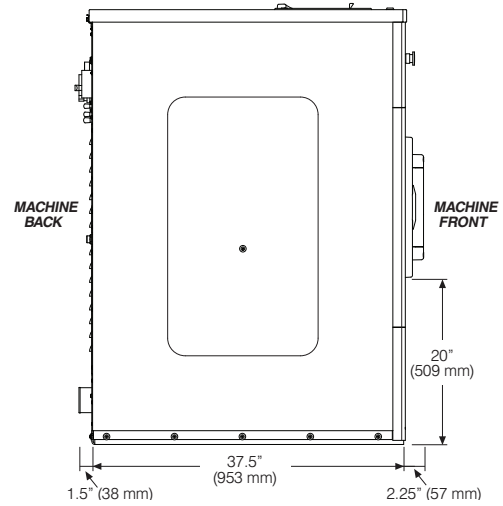
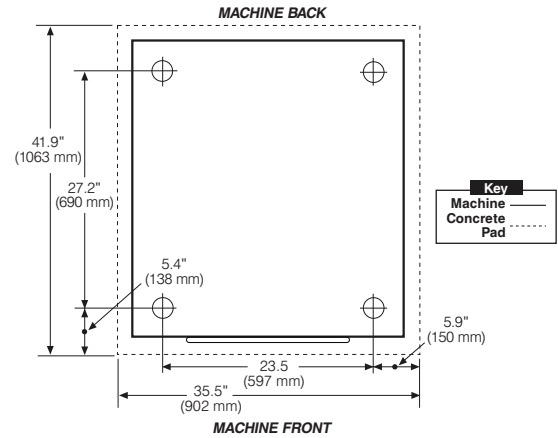

RMG055

ON-PREMISE G-FLEX HARD-MOUNT WASHER-EXTRACTOR

ARCHITECTURAL/MECHANICAL
PRODUCT SPECIFICATIONS

PRODUCT SPECS

Capacity <i>lbs</i>	55
Cylinder Diameter <i>inch</i>	27.6
Cylinder Depth <i>inch</i>	23.1
Cylinder Volume <i>cu ft</i>	8
Net Weight <i>lbs</i>	741
Crated Weight <i>lbs</i>	807
Machine Dimensions <i>inch</i> WxDxH	34.3 x 44.8 x 56.1
Door Opening <i>inch</i>	16.8
Floor to Door <i>inch</i>	19.7
Shipping Dimensions <i>inch</i> WxDxH	35.3 x 46.1 x 61.6
Washing Speed <i>rpm</i>	45
Spin Speed <i>rpm</i>	45/100/360/505/600/715
G-force	50/100/140/200
Static Force Transmitted <i>lbs</i>	1052
Dynamic Force Transmitted <i>lbs</i>	2487
Frequency of Dynamic Force <i>Hz</i>	11.9
Available Voltages/Wire Conductor/Amp	208-240/60/1, 2W+G, 10
Drain Diameter <i>inch</i>	3
Water Inlets <i>inch</i>	2 @ 3/4
Recommended Water Pressure <i>PSI</i>	30-60
Water Flow <i>gal/min</i>	16
Steam Connection <i>inch</i>	1/2
Total Power <i>kW</i>	1.05

* Specifications subject to change without notice or obligation. Contact Poseidon Textile Care at (800) 256-1073 for dimensions not shown or for clarification.

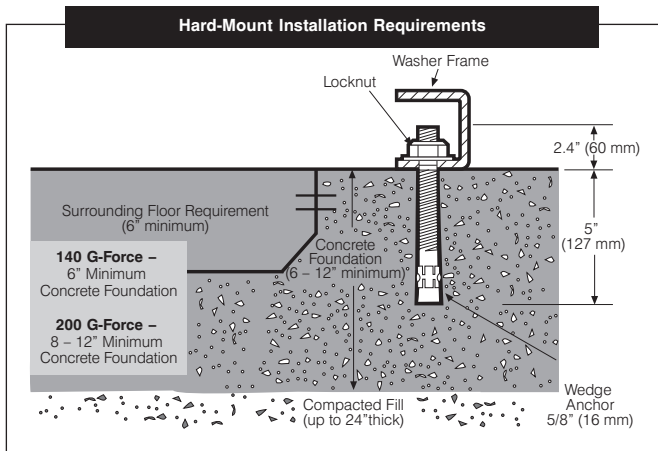
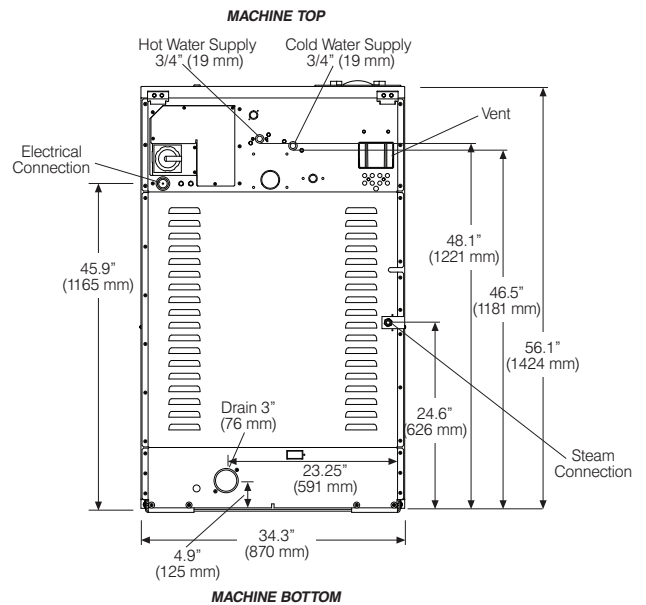
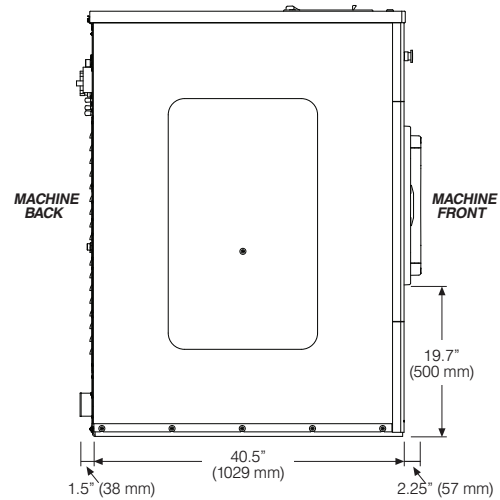
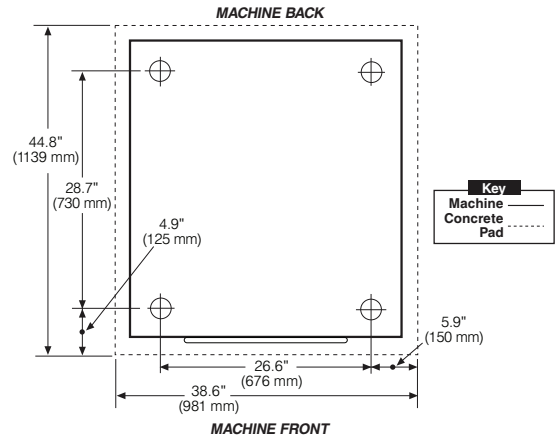

RMG070

ON-PREMISE G-FLEX HARD-MOUNT WASHER-EXTRACTOR

ARCHITECTURAL/MECHANICAL
PRODUCT SPECIFICATIONS

PRODUCT SPECS

Capacity <i>lbs</i>	70
Cylinder Diameter <i>inch</i>	30.1
Cylinder Depth <i>inch</i>	23.5
Cylinder Volume <i>cu ft</i>	9.7
Net Weight <i>lbs</i>	899
Crated Weight <i>lbs</i>	957
Machine Dimensions <i>inch</i> WxDxH	34.3 x 45 x 57.7
Door Opening <i>inch</i>	16.7
Floor to Door <i>inch</i>	21.4
Shipping Dimensions <i>inch</i> WxDxH	35.3 x 48.2 x 64.1
Washing Speed <i>rpm</i>	40
Spin Speed <i>rpm</i>	40/86/342/485/570/685
G-force	50/100/140/200
Static Force Transmitted <i>lbs</i>	1208
Dynamic Force Transmitted <i>lbs</i>	3086
Frequency of Dynamic Force <i>Hz</i>	11.4
Available Voltages/Wire Conductor/Amp	208-240/60/1, 2W+G, 15 208-240/60/3, 3W+G, 15
Drain Diameter <i>inch</i>	3
Water Inlets <i>inch</i>	2 @ 3/4
Recommended Water Pressure <i>PSI</i>	30-60
Water Flow <i>gal/min</i>	16
Steam Connection <i>inch</i>	1/2
Total Power <i>kW</i>	1.3

* Specifications subject to change without notice or obligation. Contact Poseidon Textile Care at (800) 256-1073 for dimensions not shown or for clarification.

